

SL™ Series • High Capacity Servo Lap Seal Wrapper

Robust High Capacity Design built for the Ultimate Performance in today's production environments that demand Technology driven Flexibility.



**SL-200 above shown with optional servo indexing infeed*

Standout Features of the SL-Series

- High Capacity Servo Driven Seal Head
- High Capacity Dual Roll Film Cradle
- Modular Design offers multiple infeed configurations
- Allen-Bradley® electronics package with swing arm access

MADE IN USA



High Performance Automatic Shrink Packaging Systems

SL™ Series • High Capacity Servo Lap Seal Wrapper

Conflex® ... Flexible People make Flexible Systems

Engineered for maximum capacity, flexibility, reliability and performance. Conflex® shrink packaging equipment incorporates leading-edge servo technology to take on the toughest shrink packaging challenges.

Speed and Versatility in One Durable Machine

Conflex SL™ Series Horizontal Form Fill and Seal Wrapper with leading-edge servo technology offers blazing speeds of up to 120 feet of film per minute, precision lap sealing capability, and the ultimate in packaging flexibility. The SL Series integrates seamlessly into existing lines, is easy to operate, and features hand-wheel adjustable controls and electronic eye sensors for maximum efficiency. Plus, its simple design and rugged heavy-duty steel construction ensure years of dependable use.

Conflex® SL Series Features and Benefits

- **Multi Axis servo package** – Minimizes moving parts and maximizes flexibility
- **Large full color touch screen** – For ease of operation
- **Reciprocating, servo-controlled hot knife seal system** – Precision seal placement with fewer moving parts
- **High Capacity Cradle style powered film feed** – Dual footage rolls for maximum run time
- **Triple safety system** – Protects operators and promotes a safe work environment
- **Patented Self-centering/height-limiting seal bar** – Ensures excellent uniform shrinks; requires no tools to adjust and increases line speeds
- **Supports a wider range of applications** - Infinite length and 9 1/2" height capabilities
- **Multiple options** – Adjustable height film former, thermal bottom seal, infeed length extensions, 440V operation, card-style guides, custom infeeds and more

Conflex® SL Specifications

| | |
|-----------------------------|---|
| Electrical Requirements: | 220 Volt, 30 Amp, 3 Phase |
| Air Requirements: | 80 psi, 3 cfm |
| Film Requirements: | Dual roll, single wound |
| Seal Bar Width: | 20" & 24" wide available |
| Maximum Film Width: | 42" & 48" |
| Maximum Roll Diameter: | 14" |
| Overall Machine Dimensions: | 136" L x 67" W x 94" H (includes infeed) |
| Gross Weight: | 2,400 lbs. (includes infeed) |
| Maximum Operating Speeds: | 120' film per minute |
| Deck Height on Casters: | 36.5" |
| Package Dimensions: | 3" L to Infinite L 2" W to 22" W** 1/8" H to 9 1/2" H |

*May require additional components and set-up time to run the entire size range

** Product dependent

Conflex® SL-200 Series Plan View*

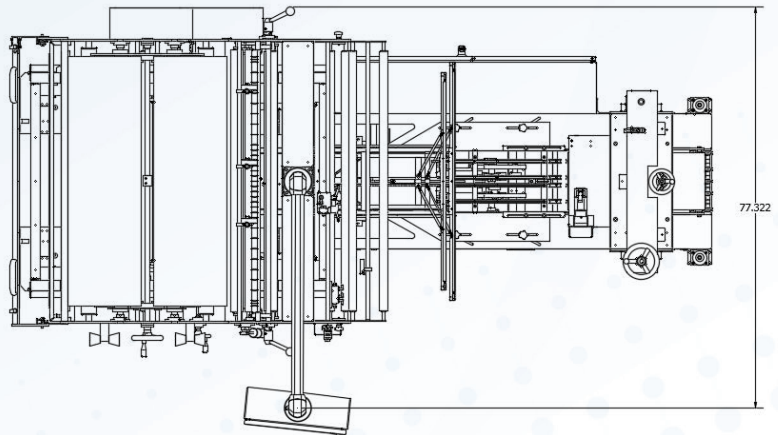

Shown with 74" Dual zone Servo infeed

The Conflex® engineering department is available to customize machinery for special product applications.

Distributed By:



Conflex Incorporated
Manufacturing Facility:
W130 N10751 Washington Dr.
Germantown, WI 53022

Toll Free: 800-225-4296
Fax: 262-512-1665
Email: info@conflex.com
www.conflex.com

