

Conflex[®]

Shrink Packaging Machinery

Advant EDGE™ Series Side-Seal Wrapper

The Next Generation in Side-Seal Equipment



AdvantEDGE 160 Rotary shown

Conflex®. Flexible People make Flexible Systems.

Engineered for maximum flexibility, reliability and performance. Conflex shrink packaging equipment incorporates leading-edge technology into designs that can take on the toughest shrink packaging challenges.

Servo-Driven for Powerful Performance

The versatile, efficient and dependable Conflex AdvantEDGE™ Series Continuous Motion Side-Seal Wrapper with servo-drive technology delivers high speed and consistency with fewer working parts for unparalleled performance. A patented Micro-V belt side sealer holds film better to provide stronger seals; convenient tool-less changeover capability ensures ease of maintenance; and its simple yet ingenious design ensures that it will integrate seamlessly with your existing packaging operation.

Conflex AdvantEDGE Series Features and Benefits

- **High-speed, continuous servo-motion**—For fast, flexible operation and improved productivity
- **Multiple cross seal modules**—Reciprocating, single and double rotary head seals
- **Touch-screen display**—Features recipe capability; optimizes ease of use and ensures consistent, superior performance
- **Solid construction**—Heavy-duty tubular steel construction; stainless steel product contact surfaces
- **Servo-controlled “bunching”****—Relaxes film between packages for stronger seals
- **Infinite length and 7-1/2" height capabilities***—Supports a wider range of applications
- **Trim seal with radiant heat**—Provides a clean, strong seal with no residue left behind
- **Servo-driven side seal**—Creates smooth and accurate product transfer
- **Servo-controlled traveling end seal***—Precision seal bar placement with fewer moving parts
- **Multiple options**—Extended 5-foot and 10-foot infeeds, card style guides, and more

* Only available in AdvantEdge 160

Conflex AdvantEDGE Series Specifications

	AdvantEdge 160	AdvantEdge 160 Rotary
Electrical Requirements	220V, 25A	220V, 25A
Air Requirements	80 psi	80 psi
Film Requirements	Centerfold	Centerfold
Seal Bar	16" wide	16" wide
Maximum Film Width	18"	18"
Maximum Roll Diameter	13"	13"
Overall Machine Dimensions	125-1/2"L x 72"W x 57"H (includes infeed)	125-1/2"L x 72"W x 57"H (includes infeed)
Gross Weight	1,700 lbs. (includes infeed)	1,700 lbs. (includes infeed)
Maximum Operating Speeds	90 ppm	200 ppm
Deck Height	35.75" 37.75"	35.75" 37.75"
Package Dimensions*	3" L infinite L 2" W to 13 1/2" W** 1/8" H to 7 1/2" H	36" L max 15" W max** 5" H max

*May require additional components and set-up time to run the entire size range.
**Product dependent.

Conflex AdvantEDGE Series Plan View

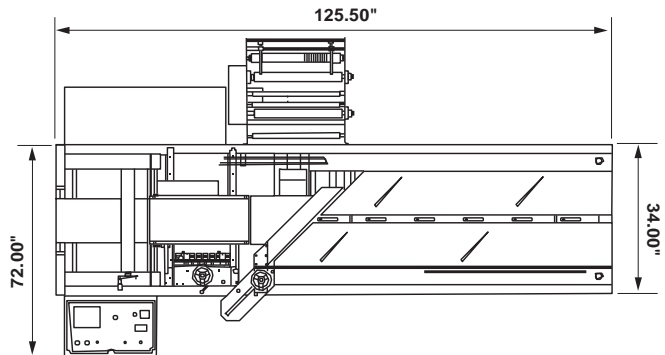

The Conflex engineering department is available to customize options for various product applications.

Distributed by:

Conflex Incorporated
Manufacturing Facility:
W130 N 10751 Washington Drive
Germantown, WI 53022
Toll Free: 800-225-4296
Fax: 262-255-4664
E-mail: info@conflex.com
www.conflex.com

© Reg. U.S. Pat. Off. Conflex and the Conflex logo are registered trademarks of Conflex Incorporated. All Rights Reserved.