

SmartFlight • Automatic Product Spacing Indexer

This automatic product spacing infeed is capable of indexing and synchronizing randomly spaced product utilizing independent high speed servo driven flight paddles.



Unique Features of the SmartFlight

- *Integrates into existing line and machinery*
- *Precise servo driven product placement and indexing*
- *Stainless version is washdown capable with Nema 4X enclosure*
- *Capable of controlling downstream equipment to match incoming rate*
- *Recipe based controls for accurate repeatability*
- *Full Allen Bradley electronics package*

MADE IN USA



High Performance Automatic Shrink Packaging Systems

SmartFlight • Automatic Product Spacing Indexer

Conflex® ... Flexible People make Flexible Systems

Engineered for maximum capacity, flexibility, reliability and performance. Conflex Inc. is committed to developing products that provide solutions to the packaging industries toughest challenges. The SmartFlight is no exception, by providing an indexing and spacing system that has the benefits of positive flighted product placement while indexing into downstream targets at high speeds.

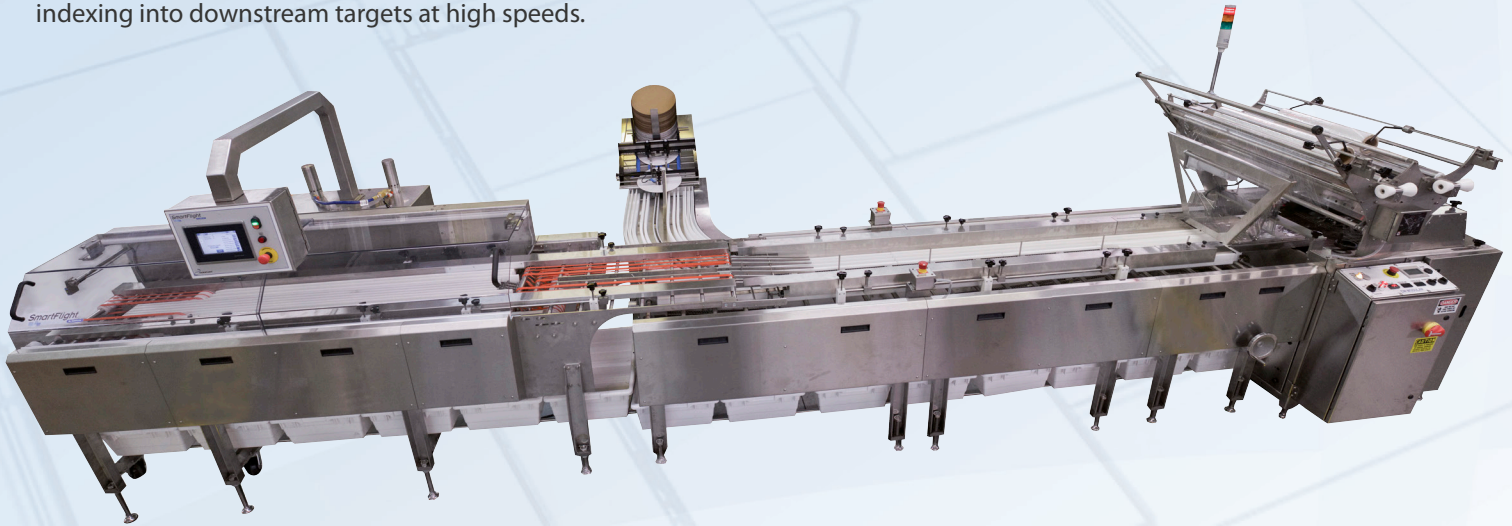

SmartFlight shown integrated with Conflex corrugated indexer and CWM-200 high speed lap sealer.

Conflex® SmartFlight Specifications

Electrical Requirements:	240 Volt, 8 FLA, 3 Phase
Air Requirements:	100 psi, 20 cfm (cabinet cooler)
Min. / Max Product Width:	7" Min. / 16" Max.*
Min. / Max Product Length:	7" Min. / 48" Max.*
Min. / Max Product Height:	1/4" Min. / 8" Max. (product dependent)
Maximum operating Speeds:	120 Products / minute**
Overall Machine Dimensions:	130" L x 48" W x 72" H (on casters)
Gross Weight:	1,400 lbs.
Deck Height on Casters:	35" up to 42" on leveling pads

*May require additional components and set-up time to run the entire size range

** Product dependent

Conflex® SmartFlight Plan View*

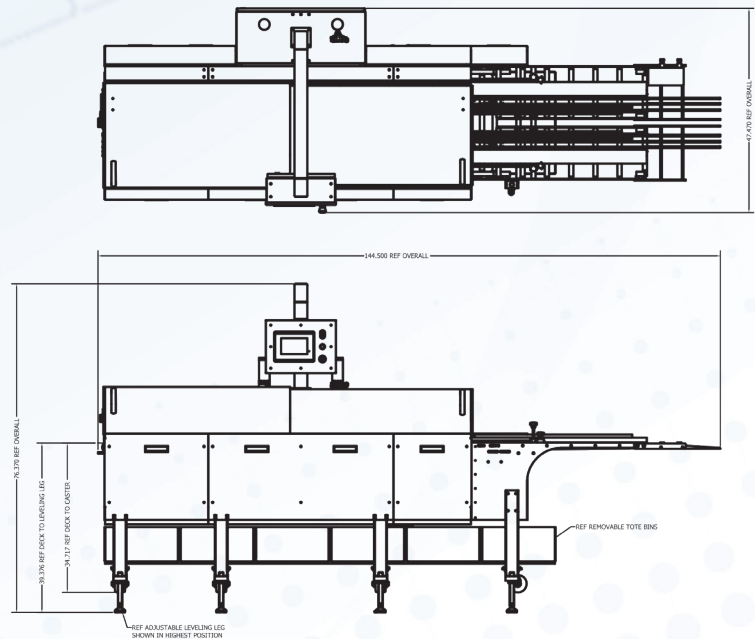

The Conflex® engineering department is available to customize machinery for special product applications.

Distributed By:



Conflex Incorporated
Manufacturing Facility:
W130 N10751 Washington Dr.
Germantown, WI 53022

Toll Free: 800-225-4296
Fax: 262-512-1665
Email: info@conflex.com
www.conflex.com

