

Conflex®

Shrink Packaging Machinery

Models E-250A

Automatic L-Sealer

Leading-Edge Design Offers Unmatched Quality and Flexibility

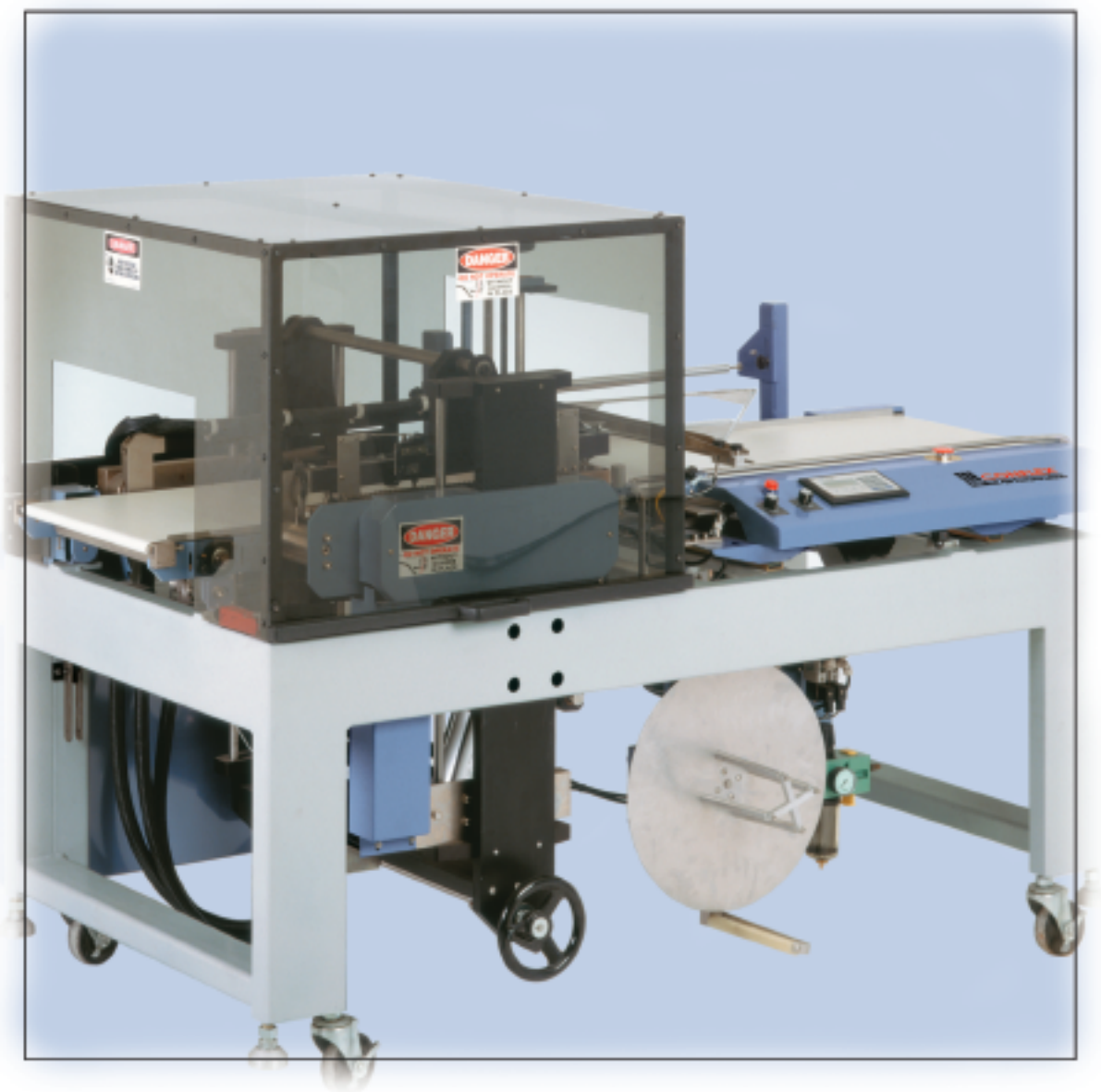

Conflex® Shrink Packaging Equipment is precision engineered for optimum performance and reliability. Contact your Conflex distributor to find out more.

Expanded Capabilities to Meet a Wide Range of Needs

The versatile Conflex E-250A Automatic L-Bar Sealer is setting a new industry standard in quality and performance. Like our E-250 Automatic L-Sealer, the E-250A is capable of “sensing” product in its conveyor and temporarily deactivates the belt advance to prevent the next package from entering, allowing for smooth, hands-free operation. In addition, the E-250A also offers adjustable sealing height, larger seal dimensions, an expanded maximum jaw opening, and variable speeds of up to 100 feet of film per minute...perfect for taking on a variety of applications.

Conflex E-250A Features and Benefits

- **PLC touch pad with recipe capabilities**—Optimizes ease of use and ensures consistent, superior performance every time
- **Fully automatic package length adjustments**—Via horizontal or vertical electric eyes; eliminates the need to stop production for adjustments
- **Tooled steel hot knife sealing system**—Eliminates need for wire replacement
- **Works well with most films**—Polyolefin, PVC and polyethylene
- **Smooth product transfer**—Allows wrapping of non-rigid products
- **Waist level film cradle with power unwind**—Maximizes operator convenience
- **Film miser/film support bar**—For optimum use and handling of film
- **Extended exit conveyor**—Facilitates smooth product discharge
- **Adjusts to your application**—Features adjustable height legs and casters; hand wheel for product height adjustment; adjustable stroke with self-centering center seal
- **Multiple options**—Include wide band seal system, anti-stat system, cassette/CD hopper, lower heated seal pad, film centerfolder, custom infeeds, stainless steel construction, and more

Conflex E-250A Specifications

Seal Dimensions	19"W x 24"L
Machine Dimensions	80"L x 59"W x 57"H
Net Weight	1,200 lbs.
Max. Pkg. Ht.	8" w/center seal
Max. Film Width	27"
Electrical	220V, 20A, 1 ph
Caster Ht.	34-3/4"
Air Requirements (min.)	1 CFM @ 80 psi

Conflex E-250A Plan View

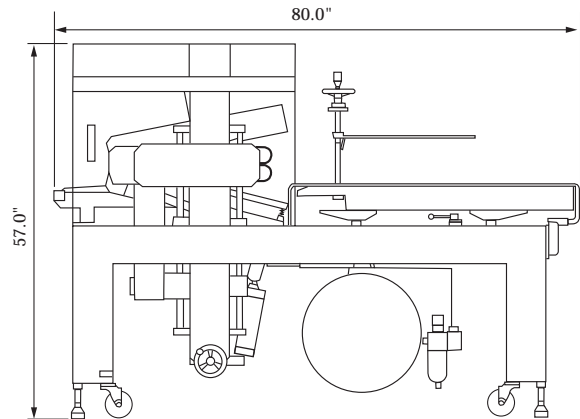

The engineering department is available to customize options for various product applications.

Distributed by:

Conflex Incorporated
Manufacturing Facility:
W130 N 10751 Washington Drive
Germantown, WI 53022
Toll Free: 800-225-4296
Fax: 262-512-1665
E-mail: info@conflex.com
www.conflex.com

Conflex and the Conflex logo are registered trademarks of Conflex Incorporated. All Rights Reserved.